

TRIMINATOR[®]
ROSINTRP

OWNER'S MANUAL
V1.5

CONTENTS

INTRODUCTION.....	2
SAFETY MESSAGES	2
ROSIN PRESS SAFETY	3
IMPORTANT SAFETY INFORMATION	3
SAFETY LABEL LOCATIONS.....	4
CONTROLS AND COMPONENTS	5
STARTING THE ROSIN PRESS	7
ROSIN PRESS OPERATION	8
ADVANCED PID CONTROL MANUAL.....	9
LIMITED WARRANTY.....	13
EXCLUSIONS FROM WARRANTY COVERAGE	14
CUSTOMER SERVICE	14

INTRODUCTION

Congratulations on your selection of the Trinator Rosin TRP! We want to help you to get the best results from your new press and to operate it safely. This manual contains the information on how to do that; please read it carefully before you set up and use your rosin press.

We suggest you read the LIMITED WARRANTY (page 13) to fully understand coverage and your responsibilities of ownership. Keep this owner's manual handy, so you can refer to it at any time. This owner's manual is considered a permanent part of the rosin press and should remain with the press if resold. The information and specifications included in this publication are those that were in effect at the time of approval for printing. Mosman Machinery Company, Inc. reserves the right, however, to discontinue or change specifications or design at any time without notice and without incurring any obligation whatsoever. No part of this publication may be reproduced without written permission.

SAFETY MESSAGES

Your safety and the safety of others are very important. We have provided important safety messages in this manual and on the Trinator. This information alerts you to potential hazards that could hurt you or others. Please read these messages carefully. Of course, it is not practical or possible to warn you about all the hazards associated with operating or maintaining a hydraulic press. You must use your own good judgment.

You will find important safety information in a variety of forms:

Safety Labels - located on the rosin press.

Instructions - how to use this rosin press correctly and safely.

Safety Messages - preceded by a safety alert.

A symbol and one of two signal words: **DANGER, CAUTION**. These signal words mean:



You **WILL** be **KILLED** or **SERIOUSLY HURT** if you don't follow instructions.



You **CAN** be **KILLED** or **SERIOUSLY HURT** if you don't follow instructions.

Each message tells you what the hazard is, what can happen, and what you can do to avoid injury.

Damage Prevention Messages - You will also see other important messages that are preceded by the word **NOTICE**. This word means:



Your rosin press or other property can be damaged if you don't follow instructions.

ROSIN PRESS SAFETY

IMPORTANT SAFETY INFORMATION

Trinator rosin presses are designed to extract essential elements from plants containing resin glands utilizing heat and pressure and from a variety of herbal material. Other uses could result in injury to the operator or damage to the rosin press and or other property. Injuries and property damage arising from the use of the Trinator rosin press can be prevented by following all instructions in this manual and on the rosin press. The most common hazards are discussed below, along with the best way to protect yourself and others.

OPERATE ON FLAT SURFACE

To avoid overturning, only operate the rosin press on flat, hard, durable surfaces. Preferably at table height or higher for best access and operator visibility. Press is heavy and must be positioned on a flat surface so as to prevent any accidental upset or tip-over.

AVOID CONTACT WITH HEAT PLATENS

Heat platens can operate at temperatures up to 225 degrees fahrenheit. Prolonged contact can cause serious burns. Note red indicator light on power button indicating power ON and platens hot.

TURN ELECTRIC POWER OFF AND UNPLUG WHEN NOT OPERATING THE ROSIN PRESS

If you need to leave the rosin press for any reason, always turn electric power off.

MANUAL HYDRAULIC PUMP

Do not place fingers or other body parts in area between heat platens when hand pumping hydraulic pump. Pinching or crushing injuries could result.

AIR OR ELECTRIC HYDRAULIC POWER OPTIONS

Do not place fingers or other body parts in area between heat platens.
Keep BOTH hands on power unit controls at all times when hydraulically closing press platens.

All rosin press loading and closing functions are to be activated by a single person operator ONLY.

OPERATOR RESPONSIBILITY

Know how to stop and reverse press action immediately in case of emergency. Understand the use of all rosin press controls. Never permit anyone to operate the rosin press without proper instruction. Do not let children operate the rosin press.

SAFETY LABEL LOCATIONS

The labels shown here contain important safety information. Please read them carefully. These labels are considered a permanent part of your rosin press. If a label comes off or becomes hard to read, promptly contact your authorized Triminators dealer for a replacement.

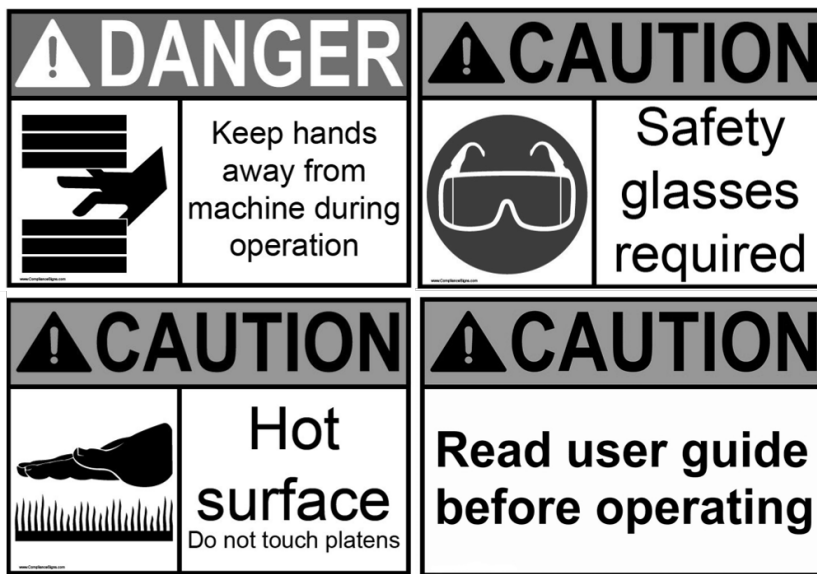
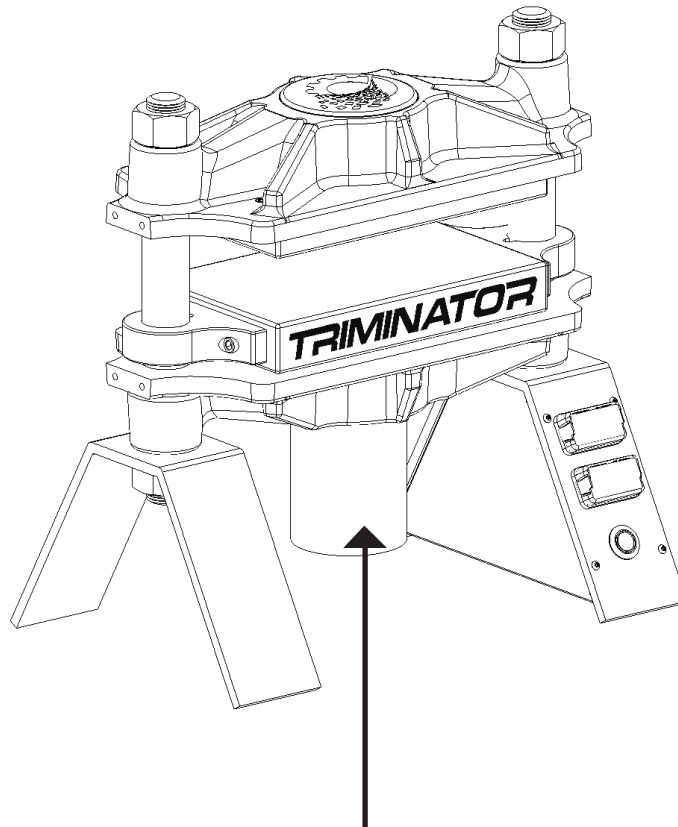

CONTROLS AND COMPONENTS

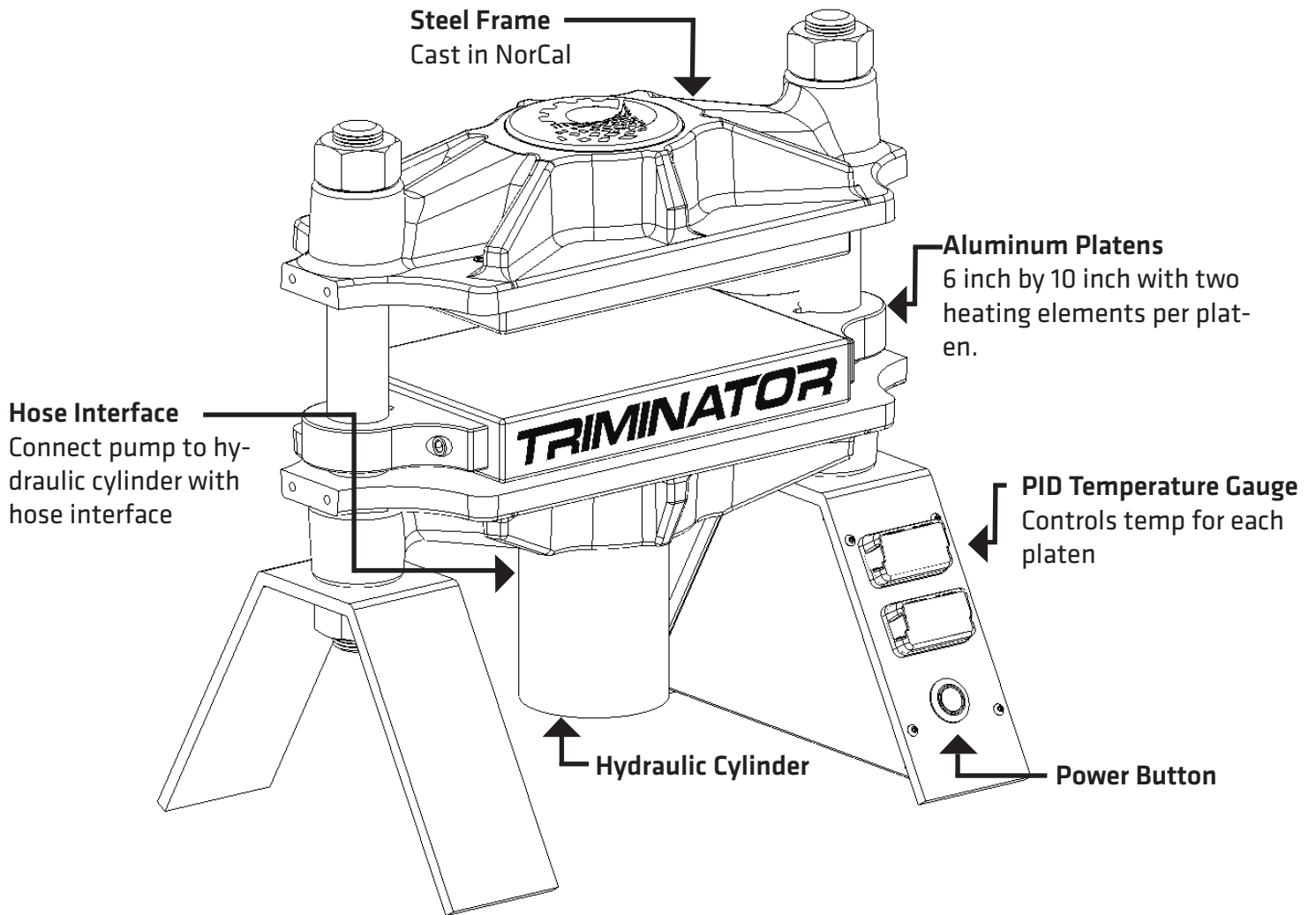

CONTROLS AND COMPONENTS (CONT)

BEFORE OPERATION

Read and understand this manual. Know what the controls do and how to operate them. Familiarize yourself with the rosin press and its operation before you begin using it. Know how to quickly shut off the machine in case of an emergency.

Your safety is your responsibility.

IS YOUR ROSIN PRESS READY FOR OPERATION?

For your safety, and to maximize the service life of your equipment, it is very important to take a few moments each time before you operate the press to check its condition. Be sure to take care of any problem you find before you operate the rosin press.

Improperly maintaining this rosin press, or failing to correct a problem before operation, could cause a malfunction which could cause you to be seriously injured.

Always perform a pre-operation inspection before each operation, and correct any problem.

Before beginning your pre-operation checks, be sure the rosin press is on a level surface, the power button is in the OFF position, and power cord is unplugged.

CHECK THE GENERAL CONDITION OF THE ROSIN PRESS

Check each control for proper operation.

Check parts for wear. Replace if necessary.

Check that all nuts, bolts, and clamps are tightened appropriately.

STARTING THE ROSIN PRESS

CONNECT POWER CORD

Connect the Rosin Press power cord to a 20A 120V AC circuit. Optional air or electric power units may be plugged in to the same outlet. Do not connect and disconnect the power cord with wet hands. Do not operate in the rain.

NOTICE

Rosin Press machine alone draws approximately 10 amps. With optional electric power unit, total current draw will be approximately 20 amps.

ATTACH HYDRAULIC PUMP UNIT

Connect hose from manual, air, or electric hydraulic pump to Rosin Press cylinder. Engage hose fitting by pushing into mating cylinder and turning locking ring to secure.

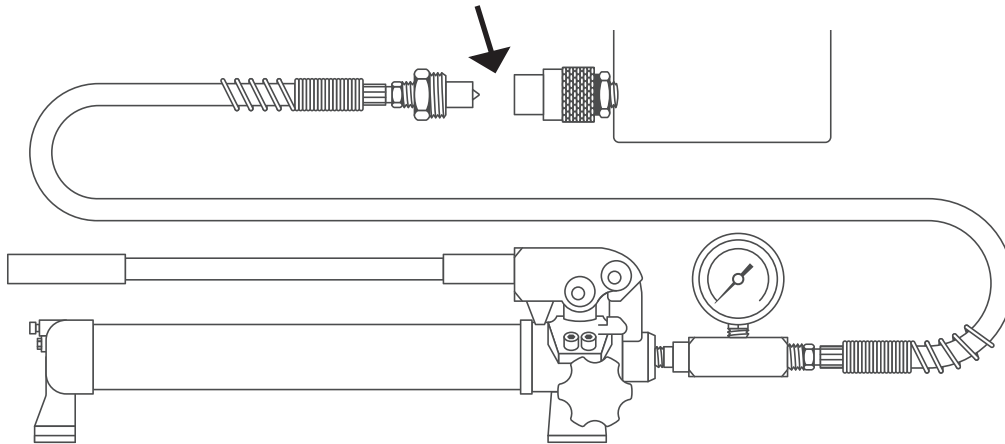

STARTING THE ROSIN PRESS

Push power button in. Button will illuminate in red color indicating power on condition. Heat platens will take up to 15 minutes to heat and stabilize at desired temperature.

STOPPING THE ROSIN PRESS

To turn off Rosin Press, push power button in, release, red light will stop, and power will be in off mode.

DISCONNECT POWER CORDS

Unplug Rosin Press cord from power outlet. Unplug optional air or electric hydraulic power unit from AC outlet.

COOL DOWN

Allow sufficient time in power off mode for Rosin Press to cool before attempting to move machine.

NOTICE: Be sure to hold the plug when disconnecting the power cord from the electrical outlet. Do not disconnect by pulling on the power cord.

ROSIN PRESS OPERATION

Program optimal press platen temperature into temperature control (PID) units. Typically press operation will be between 195 to 220 degrees Fahrenheit.

To adjust set value temperature on PID control push and hold up arrow button for three seconds.

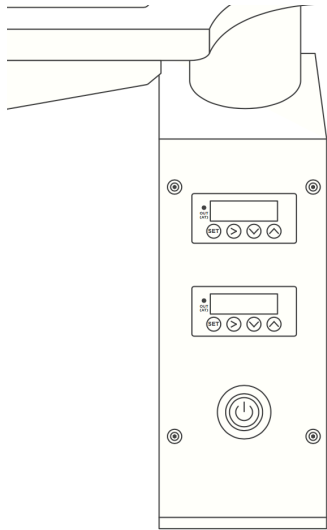

Increase temperature

Press and hold the up button for 3 seconds. At desired temp, press the set button.

Decrease temperature

Hold the up arrow for 3 seconds. Then, press the down arrow until the desired temp is shown. Press the set button.

Check current temperature setting

Press the up button and the set temp will show. Press the set button, and the current temp will show again.

Wait at least 15 minutes after Rosin Press starts for press platens to reach desired and stable temperature. Note that some slight fluctuation is normal.

Insert prefilled filter bag packet(s) and PTFE catchment paper between press platens. To optimize press performance, position bags close to center of press platen surface. Multiple small bags may be used.

Close press platens by activating hydraulic pump, either by hand unit or with power pump options. Pressure gauge on pump will read approximately 500 psi. Wait until liquid can be seen forming along packet edges, then slowly increase pump pressure to 7000 psi. Combination of heat and intense pressure will push out all liquid rosin material from filter bag packets.

Maximum recommended pressure as viewed on pump gauge is 7000 psi.. Approximately 20 Tons at press platens.

When all rosin has been extracted, release pump pressure. Platens will return to open position. Remove spent filter bag packet and catchment paper, reload with fresh material, and repeat press operation.

When filter bag packet and catchment paper have cooled sufficiently, dried rosin material may be removed.

PID TROUBLESHOOTING

Your press has a PID controller on it, it has a temperature sensor and two heating cartridges per platen. These elements communicate with each other in a permanent closed loop controlled by a microcomputer.

Your PIDs come preset with standard operational parameters however some users may want to adjust or fine tune the PIDs further. For this reason we have included the following guide for advanced troubleshooting.

PID Standard Operational Parameters

The below graphic shows the pre-set advanced settings menu and general setting menu on the Rosin TRP.

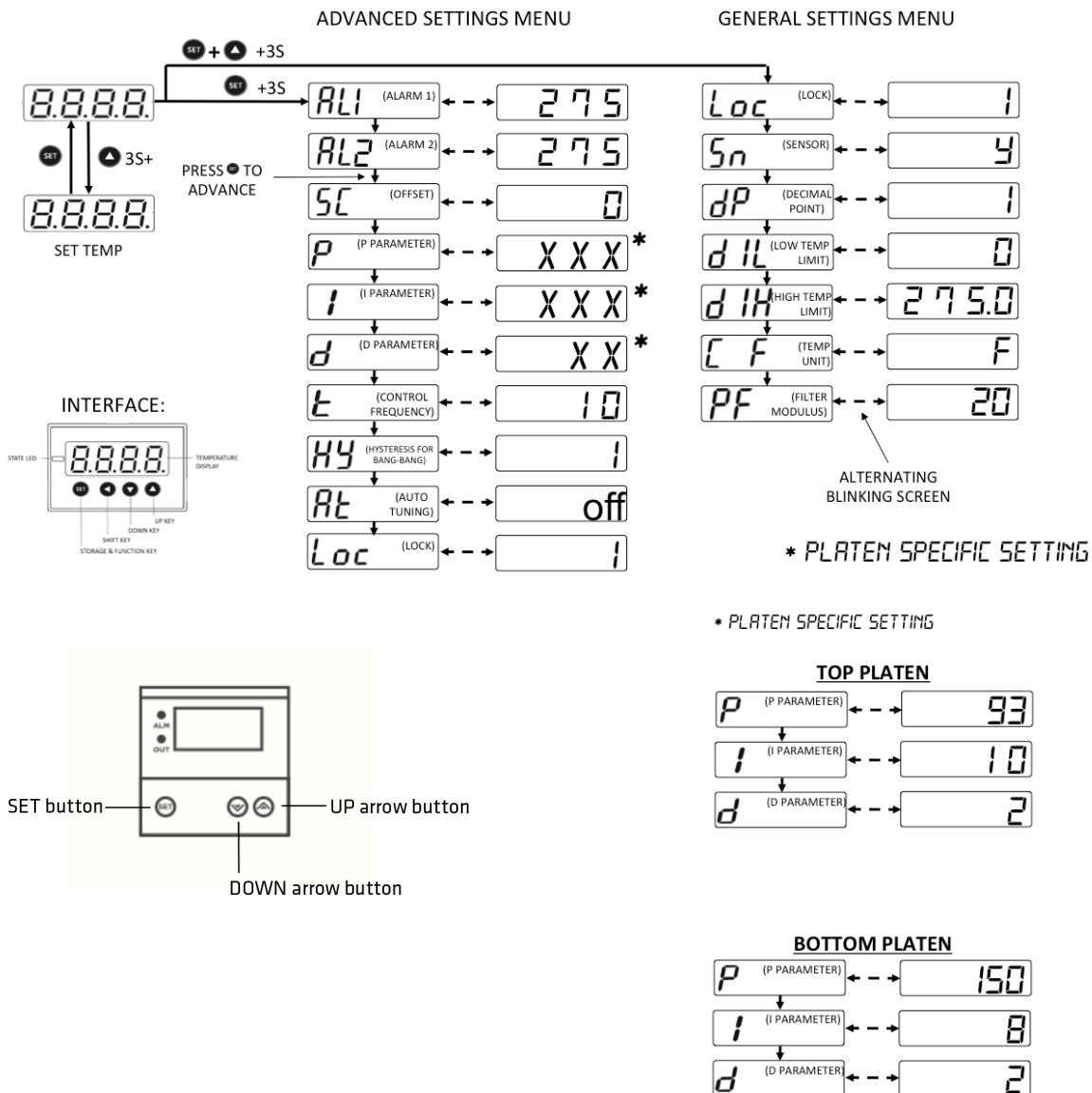

PID TROUBLESHOOTING (CONT)

Troubleshooting the PID

If you find a platen or platens are not functioning properly, you may wish to reset the PID. Some of the most common issues people may have are below.

Press Doesn't Reach the Preset Temperature

A press that doesn't reach the preset temperature usually has the PID parameters set up incorrectly. Verify "standard operational parameters" on page 9. Go through all the settings and verify that they match. If they don't match, write down the current PID parameters. To reset parameters, follow steps on page 11 & 12.

Temperature Gun Shows a Different Temperature

Temperature guns can be highly inaccurate when reading temperatures in reflective surfaces or at an angle. We suggest an actual thermometer and some kind of lubricant between the tip of the reader and the specific surface area for which you want to read the temperature.

If you want to use a temperature gun, you should paint a black spot on the surface of the platen with some kind of permanent marker, and take the reading as close as possible to that spot, and perpendicular to the surface.

When it's determined that a reset is necessary, the following is a guide showing how to properly reset a single PID. You will need to repeat the steps for each PID that needs to be reset.

PID TROUBLESHOOTING (CONT)

Unlock General Settings PID Menu 1

- » Push SET button and hold for 3 seconds.
- » Push SET button to advance through settings until you get to the screen **Loc**.
- » Push UP to increase number or DOWN arrow to decrease number until you get to the number 0, then push SET button again until you get to the main screen or allow the screen to timeout to return to the main screen.

Unlock General Settings PID Menu 2

- » Push SET button and UP arrow and hold for 3 seconds.
- » Push SET button to advance through settings until you get to the screen **Loc**.
- » Push UP to increase number or DOWN arrow to decrease number until you get to the number 0, then push SET button again until you get to the main screen or allow the screen to timeout to return to the main screen.

Now the PID is unlocked and the parameters can be reset.

Reset the General Settings PID Parameters to Default Values Menu 1

The following settings have been optimized by Triminators engineers to provide the best platen performance. Refer to the PID Manufacturing Settings graph. Follow these settings exactly.

- » Push SET button and hold for 3 seconds.
- » Push SET button to advance through settings.
- » Push UP to increase number or DOWN arrow to decrease number until you get to the desired value. Enter the setting based on the numbers provided in the PID Manufacturing Settings graph.
- » Push SET button again and continue setting all the values.

For P, I, D, the settings are dependent on top or bottom platen.
Use chart numbers shown in the graphic below to set the platens.

* PLATEN SPECIFIC SETTING

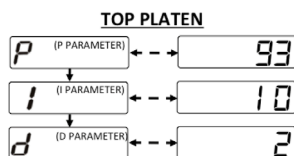

- » Once all values have been set, push SET button again until you get to the main screen or allow the screen to timeout to return to the main screen.

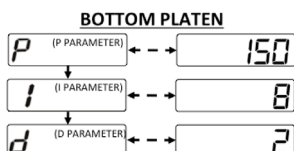

PID TROUBLESHOOTING (CONT)

Once you have your PID parameters set. Lock your PID Menu to prevent any changes.

Relock General Settings PID Menu 1

- » Push SET button and hold for 3 seconds.
- » Push SET button to advance through settings until you get to the screen **Loc**.
- » Push UP to increase number or DOWN arrow to decrease number until you get to the number 1, then push SET button again until you get to the main screen or allow the screen to timeout to return to the main screen.

Relock General Settings PID Menu 2

- » Push SET button and UP arrow and hold for 3 seconds.
- » Push SET button to advance through settings until you get to the screen **Loc**.
- » Push UP to increase number or DOWN arrow to decrease number until you get to the number 0, then push SET button again until you get to the main screen or allow the screen to timeout to return to the main screen.

Now the parameters are locked which will prevent any accidental changes.

Setting Maximum Platen Temperature

If you prefer to set a maximum platen temperature, you'll need to unlock the General Settings PID Menu 1 and 2 before following the steps below.

- » Push SET button and UP arrow and hold for 3 seconds.
- » Push SET button to advance through settings until you get to the screen **d1H**.
- » Push UP to increase number or DOWN arrow to decrease number until you get to the maximum temperature, then push SET button again until you get to the main screen or allow the screen to timeout to return to the main screen.

LIMITED WARRANTY

TRIMINATOR EQUIPMENT

This warranty is limited to the Trinator Machine distributed by Mosman Machinery Company, Inc., Nevada City, California 95959. The following warranty applies to all Trinator products purchased directly or from retail outlets after January 1, 2013.

LENGTH OF WARRANTY

All Trinator products are covered under this warranty for a length of 24 months from the date of original purchase.

TO QUALIFY FOR THIS WARRANTY:

The product must be purchased in the United States, directly from Mosman Machinery Company, Inc. or from a dealer authorized by Mosman Machinery Company, Inc. to sell those products. This warranty applies to the first retail purchaser during the applicable warranty time period.

WHAT WILL BE REPAIRED OR REPLACED UNDER WARRANTY:

Mosman Machinery Company, Inc. will repair or replace, at its option, any part that is proven to be defective in material or workmanship under normal use and proper maintenance as prescribed in this Manual during the applicable warranty time period. Warranty repairs and replacements will be made without charge for parts or labor. Any part replaced under warranty becomes the property of Mosman Machinery Company, Inc. All new parts replaced under warranty will be considered as part of the original product, and any warranty on those parts will expire coincident with the original product warranty.

TO OBTAIN WARRANTY SERVICE:

You must call Trinator/Mosman Machinery Company, Inc. to discuss the warranty issue.

Phone: 530.265.4277

Following the qualifying phone conversation Mosman Machinery Company, Inc. may direct you to do one of the following:

At your expense, take the Trinator product, part to be replaced, or the equipment on which the part to be replaced is installed, and a proof of purchase to the Trinator dealer from whom you originally purchased the product, during the dealer's normal business hours.

Alternatively, Mosman Machinery Company, Inc. may direct you in writing (email) to deliver your product to a different location at a distance less than or equal to the distance from your current location to the dealer from which you originally purchased the product.

LIMITED WARRANTY (CONT)

EXCLUSIONS FROM WARRANTY COVERAGE

The following items and conditions are excluded from warranty coverage:

Any damage or deterioration resulting from the following:

- » Neglect of the periodic maintenance as specified in this manual.
- » Improper repair or maintenance.
- » The use of non-genuine Trimator parts and/or products other than those approved by Mosman Machinery Company, Inc.
- » Exposure of the product to chemical agents, sea water, sea breeze, salt or other damaging environmental phenomena.
- » Collision, deterioration, neglect, unauthorized alteration, misuse, incorporation or use of unsuitable attachments, products or parts.
- » Natural wear and tear (natural fading of painted or plated surfaces, sheet peeling and other natural deterioration).

Consumable parts: Mosman Machinery Company, Inc. does not warrant parts that deteriorate due to natural wear and tear.

Cleaning, adjustment, and normal periodic maintenance work (lubrication, blade sharpening, belt adjustments).

Any product that has ever been declared a total loss or sold for salvage by a financial institution or insurer.

DISCLAIMER OF CONSEQUENTIAL DAMAGE AND LIMITATION OF IMPLIED WARRANTIES:

Mosman Machinery Company, Inc. disclaims any responsibility for loss of time or use of the product, transportation costs, commercial loss, or any other incidental or consequential damage. Any implied warranties are limited to the duration of this written limited warranty. This warranty gives you specific legal rights, and you may also have other rights which vary from state to state.

CUSTOMER SERVICE

For all customer service inquiries or to help you diagnose any issues with your machine contact Trimator directly:

Phone: 530.265.4277

Email: support@thetriminator.com

Web: www.theTrimator.com

