

XL DRY KIEF KIT QUICK START GUIDE

INSTALLATION

1 POWER DOWN

With the motor off, and power cords unplugged, set the XL Dry in a horizontal position.

2 RELEASE SHEAR BAND TENSION

Turn the shear band tension knob clockwise to loosen tension and flip the pawl off the ratchet so it is no longer in contact.

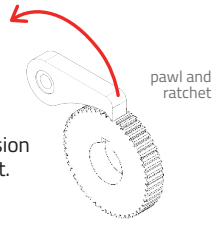

3 REMOVE TRIM DRUM

Loosen the drum retainer block set screws on either end of the drum and slide the drum retainers up.

Retract the motor drive wheel away from the drum by pulling the rubber-coated lever, located on the out-feed side of the control box.

Employing two people, slide the drum gently from the machine and set it on a non-abrasive surface.

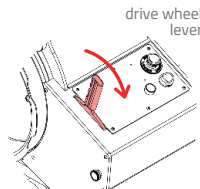
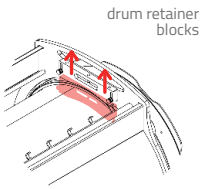

4 REMOVE SHEAR BAND

Gently lift the shear band off of the metal tabs and out of the machine. Place it on a non-abrasive surface.

5 INSTALL KIEF DRUM

Utilizing two or more people, slide the drum gently into the machine.

Ensure the drive wheel is aligned with the groove. Re-engage the drive wheel by pulling the spring pin and releasing the lever towards the drum.

Slide both drum retainer blocks down until they reach the bottom of their range and tighten set screws.

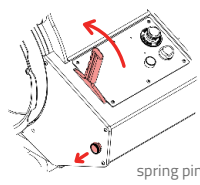
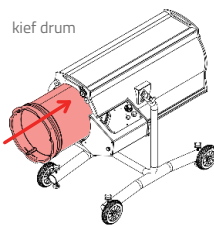

CHECK THE XL DRY USER GUIDE FOR MORE DETAILED DRUM INSTALLATION INSTRUCTIONS

OPERATION

1 LOAD

With the kief drum and kief collection trays installed, tilt your XL Dry Trimmer back to the load position. Fill the drum with trim, $\frac{1}{2}$ - $\frac{3}{4}$ full.

Note: Overfilling will lower quality and processing speed.

Tip: For best results, use frozen trim.

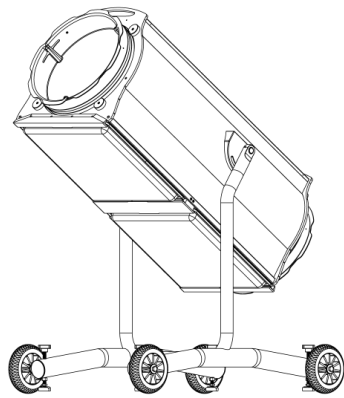

2 ICE

If using CO₂ ice, add at a ratio of 70-80% trim to 30-20% dry ice.

Replace the end cap and let sit 5-10 minutes to allow the machine and trim to get cold.

Note: Dry ice must be in crushed or pellet form. Large chunks of dry ice will damage the screen.

3 TUMBLE

Tilt the XL Dry into the horizontal position. Set the run timer for up to 10 minutes.

Note: Drum must be in horizontal position throughout the entire process.

Tip: If you wish to separate the different kief qualities: run 5 minutes, remove first batch of kief, then run again for 5 minutes.

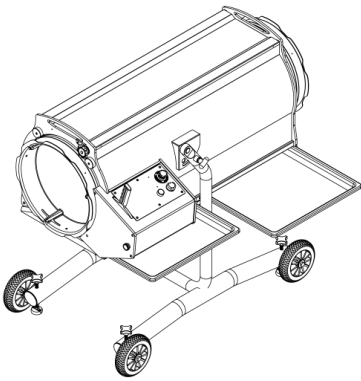

4 COLLECT

When the tumble is complete, keep the machine in the horizontal position:

- Carefully slide the kief trays out.
- Brush off any accumulated kief around the machine edges into kief tray.
- Carefully remove drum, and brush off accumulated kief.

CLEANING

Hand clean with soap and water when you notice output diminishing.

QUESTIONS?

CONTACT A TRIMINATOR EXPERT

1-530-265-4277

INFO@THETRIMINATOR.COM

THETRIMINATOR.COM

@THETRIMINATOR

